

# Relais REL5A-DALI-2

EAN 4007841 082109

Article number 082109

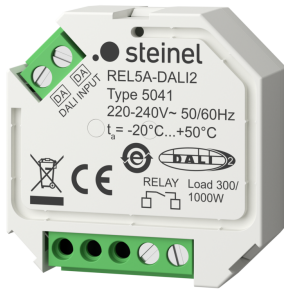

DALI-2



CE

## Function description

With the relay it is possible to integrate circuits into the DALI control: up to 50 pieces of up to 300 W LED luminaires (with a capacity of less than 176  $\mu\text{F}$ ). Control of the DALI bus in accordance with the DALI-2 standard to IEC 62386 Part 208. Separate power supply so that only one DALI device per 2 mA is required. Simple installation in standard flush-mounted boxes. Factory setting: relay closed.

## Technical specifications

Dimensions (L x W x H)	20 x 46 x 45 mm
With motion detector	No
Manufacturer's Warranty	5 years
Settings via	App, Bus
With remote control	No
PU1, EAN	4007841082109
Type	Other
Colour	white
Includes corner wall mount	No
IP-rating	IP20
Ambient temperature	-20 – 50 °C
Mains power supply	220 – 240 V / 50 – 60 Hz
Switching output 1, resistive	1000 W
Switching output 1, number of LEDs / fluorescent lamps	50 pcs.

LED lamps > 8 W	300 W
Capacitive load in $\mu\text{F}$	176 $\mu\text{F}$
Number of Dali users	1
With bus coupling	No
Sneak-by guard	No
Capability of masking out individual segments	No
Mechanical scalability	No
Functions	Relay output
Basic light level function	No
Main light adjustable	No
Twilight setting TEACH	No
Constant-lighting control	No
Typical current consumption at 16V input voltage	2 mA
Max. Current consumption at 10V input voltage in regular operation	2 mA

# Relais REL5A-DALI-2

EAN 4007841 082109  
Article number 082109

## Dimension Drawing

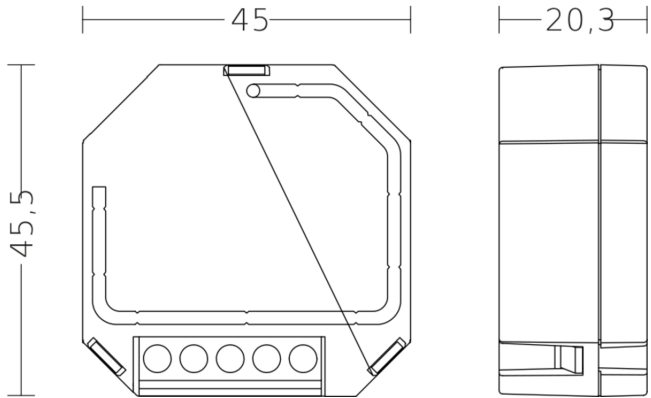

## Circuit diagram 1

